

Intel® Core™ i7-800 Processor Series and the Intel® Core™ i5-700 Processor Series Based on Intel® Microarchitecture (Nehalem)



“By measuring the benefit of the performance gain against the power cost, Intel was able to design Intel microarchitecture (Nehalem) to deliver greater power efficiency at any power envelope.”

Jeff Casazza
Intel Corporation

Introducing a New Dynamically and Design-Scalable Microarchitecture that Rewrites the Book on Energy Efficiency and Performance

Since the introduction of Intel® Core™ microarchitecture in 2006 and its 2007 45nm enhancements—the Intel Core microarchitecture (Penryn) family of processors—the blistering performance and energy efficiency of Intel® microprocessors have delivered unprecedented capabilities to computer users. Now a new microarchitecture named Nehalem (the foundation of the Intel® Core™ i7-800 and Core™ i5-700 processor series) builds on these earlier microarchitectural marvels, rewriting the book on processor scalability, performance, and energy efficiency.

Intel® microarchitecture’s (Nehalem’s) energy efficiency and performance comes at a critical crossroads in computing. In the past, when a computer’s energy efficiency wasn’t a concern, nearly every architecture feature that could improve processor performance would be included without worrying about the power cost. But in an age of increasing concern for limited resources and increased energy costs, every segment (server, workstation, desktop, and mobile) is power-constrained

and designing a microarchitecture requires a different approach. Processor manufacturers must consider the power cost for whether the processor is intended for the home, data center, or ultra-light laptop.

Intel weighed every architectural feature added to Intel microarchitecture (Nehalem) against a strict power/performance efficiency threshold. If the feature couldn’t add more than a one percent performance gain for a less than three percent power cost, Intel wouldn’t add it. By measuring the benefit of the performance gain against the power cost, Intel was able to design Intel microarchitecture (Nehalem) to deliver greater power efficiency at any power envelope.

Example: Intel® Core™ i7-800 Processor Series and Intel® Core™ i5-700 Processor Series

A good example of how Intel microarchitecture (Nehalem) enables the scaling of energy efficiency and performance can be seen in the Intel Core i7-800 and Core i5-700 processor series). These two processor series incorporate a number of Intel’s innovative technologies to deliver intelligent performance. (Each of which will be discussed in more depth later in this paper.)

The Adaptability of the Intel® Core™ i7 and Core™ i5 Processors 800 and 700 Series

Performance

Maximizes performance by adapting to the workload through Intel® Turbo Boost Technology and Intel® Hyper-Threading Technology

Software Adaptable

The processor adapts to the way your application wants to run

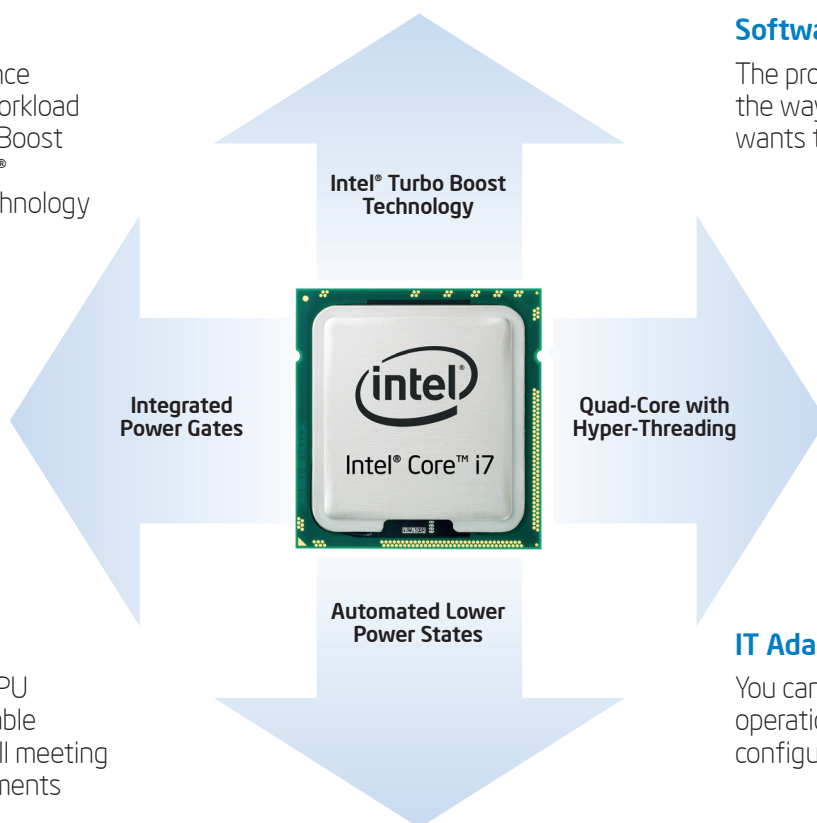

Energy Efficiency

Automatically puts CPU into the lowest available power state while still meeting performance requirements

IT Adaptable

You can enable automatic operation or selectively configure for manual control

▪ **Intel® Turbo Boost Technology!** This technology (in combination with Intel® Intelligent Power Technology described below), delivers performance on demand, allowing processors to operate above the rated frequency to speed specific workloads and drop back down to reduce power consumption during low utilization periods.

▪ **Intel® Hyper-Threading Technology!** This well-known Intel innovation provides more performance for applications designed for parallel, multi-threaded execution by reducing computational latency and making optimal use of every cycle. Intel® Hyper-Threading Technology benefits from this latest Intel microarchitecture's larger caches and massive

memory bandwidth, delivering greater throughput and responsiveness for multi-threaded applications.

▪ **Power Gates** enable unused cores to be completely switched off essentially eliminating leakage current from unused cores. This greatly reduces power consumption during both idle and peak loads.

Unlocking All the Power of Intel's 45nm Hi-k Metal Gate Process Technology

Intel microarchitecture (Nehalem) marks the next step (a "tock") in Intel's rapid "tick-tock" cadence for delivering a new process technology (tick) or an entirely new microarchitecture (tock) every year.

Intel microarchitecture (Nehalem) was designed from the ground up to capitalize on all the advantages of Intel's industry-leading 45-nanometer (nm) Hi-k metal gate silicon technology. This process technology is one of the biggest advancements in fundamental transistor design in 40 years. It uses a unique material combination of Hi-k gate dielectrics and conductors to enable Intel to continue record-breaking PC, laptop, and server processor performance while reducing the electrical leakage from transistors that can hamper chip and PC design, size, power consumption, and costs.

Intel's 45nm Hi-k silicon process technology increases transistor switching speeds to enable higher core and bus clock frequencies and thus more performance in the



Figure 1. Intel® microarchitecture (Nehalem).

same power and thermal envelope. This performance efficiency is helping Intel extend Moore's Law (a high-tech industry axiom that transistor counts double about every two years to deliver ever more functionality at exponentially decreasing cost) well into the next decade.

An Overview of Intel's New Microarchitecture

Intel microarchitecture (Nehalem) continues Intel's philosophy of focusing on improvements in how the processor uses available clock cycles and power, rather than just pushing up ever higher clock speeds and energy needs. The goal is to do more in the same power envelope—or even reduced envelopes. In turn, like its predecessor (Penryn), Intel microarchitecture (Nehalem) includes the ability to process up to four instructions per clock cycle on a sustained basis compared to just three instructions per clock cycle or less processed by other processors. However, the biggest innovations offered by Intel microarchitecture (Nehalem) come from new optimizations of the individual cores and the overall multi-core microarchitecture to increase single-thread and multi-thread performance.

Intel microarchitecture (Nehalem) includes these performance and power management innovations:

- Dynamically managed cores, threads, cache, interfaces, and power
- Intel Hyper-Threading Technology, a capability which enables running two simultaneous threads per core—an amazing eight simultaneous threads per quad-core processor and 16 simultaneous threads for dual-processor, quad-core designs. This feature provides an energy efficient means of increasing performance for multi-threaded workloads.
- Innovative extensions to the Intel® Streaming SIMD Extensions 4 (Intel® SSE4) that center on enhancing Extensible Markup Language (XML), string, and text processing performance
- Superior multi-level cache, including an inclusive shared L3 (last-level) cache
- Performance-enhanced dynamic power management
- On the design side, Intel microarchitecture (Nehalem) enables optimal price/performance/energy efficiency

An In-Depth Look at Key Features

We will now provide a more in-depth look at some of the top features of Intel microarchitecture (Nehalem) that are available in the Intel Core i7-800 and Core i5-700 processor series.

1. Intel® Turbo Boost Technology

Intel® Turbo Boost Technology is an innovative feature that automatically allows active processor cores to run faster than the base operating frequency when there is available headroom within power, current, and temperature specification limits. This enables Intel Core i7-800 processor series and the Intel Core i5-700 processor series to deliver extra performance when and where it is needed (see Figure 2). This can be particularly advantageous in speeding up the processing of light or lightly threaded workloads.

Intel Turbo Boost Technology is activated when the operating system requests the highest processor performance state. Headroom is dynamically assessed by continual measurement of temperature, current draw, and power consumption. The maximum frequency of Intel Turbo

Higher Performance on Demand

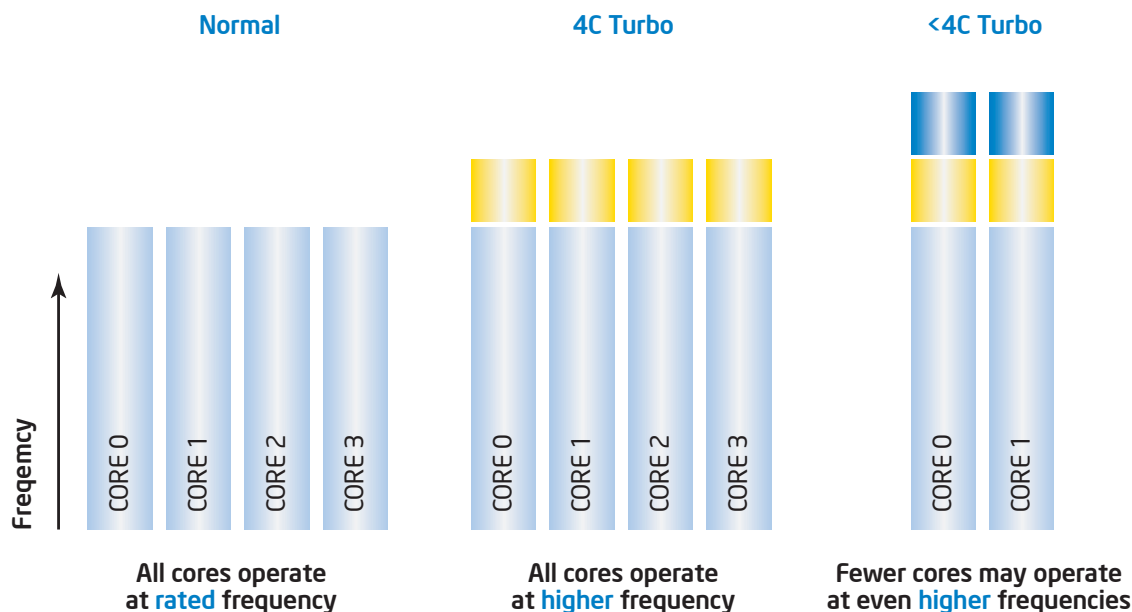

Figure 2. Intel® Turbo Boost Technology increases performance by increasing processor frequency and enabling faster speeds when conditions allow.

Boost Technology is dependent on the number of active cores. The amount of time the processor spends in the Intel Turbo Boost Technology state depends on the workload and operating environment.

Any of the following can set the upper limit of Intel Turbo Boost Technology on a given workload:

- Number of active cores
- Estimated current consumption
- Estimated power consumption
- Processor temperature

The number of active cores at any given instant dictates the upper limit of Intel Turbo Boost Technology. For instance, a core is considered “active” if it is in the “C0” or “C1” state; a core in the “C3” or “C6” state is considered “inactive.” (C-states are the power conservation states of a processor core.)

The upper limits will vary on a per-processor number basis. For example, a particular processor may allow up to two frequency

steps (266.66 MHz) when just one core is active and one frequency step (133.33 MHz) when two or more cores are active. Therefore, higher C-state residency (“C3” or “C6”) on some cores will generally result in increased core frequency on the active cores. The upper limits are further constrained by temperature, power, and current. These constraints are managed as a simple closed-loop control system. If measured temperature, power, and current are all below factory-configured limits, and the operating system (OS) is requesting maximum processor performance, the processor automatically steps up core frequency (+133.33 MHz) until it reaches the upper limit dictated by the number of active cores. When temperature, power, or current exceed factory-configured limits—and you are above the base operating frequency—the processor automatically steps down core frequency (-133.33 MHz) in order to reduce temperature, power, and current. The processor then monitors processor temperature, power, and current, and continuously re-evaluates.

Note: When Intel Turbo Boost Technology is requested by the OS, the processor will commonly operate between the maximum Intel Turbo Boost Technology frequency and the base operating frequency. All active cores in the processor will operate at the same frequency. Even at frequencies above the base operating frequency, all active cores will run at the same frequency and voltage. Due to the way the system firmware and OS communicate, the software may never detect core clock frequencies above the operating frequency.²

2. Intel® Hyper-Threading Technology

Many applications lend themselves to parallel, multi-threaded execution. Intel Hyper-Threading Technology enables simultaneous multi-threading within each processor core, up to two threads per core or eight threads per quad-core processor (see Figure 3, next page). Hyper-threading reduces computational latency, making optimal use of every clock cycle. For example, while one thread is waiting for a result or event, another thread is executing in that core to maximize the work from each clock cycle.

Intel® Hyper-Threading Technology

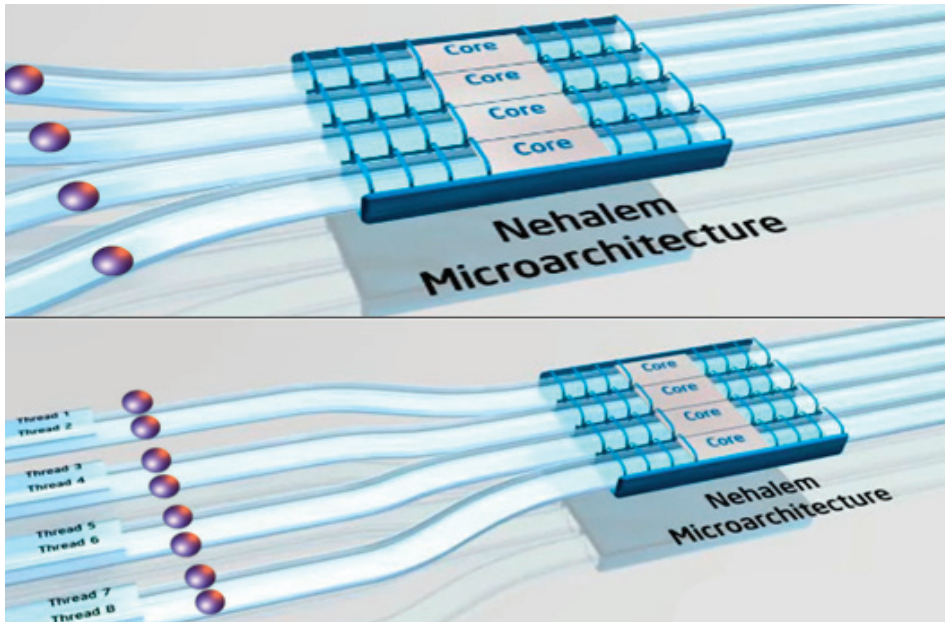

Without HT Technology

With HT Technology

Figure 3. Intel® Hyper-Threading Technology enables simultaneous multi-threading of eight threads per quad-core processor.

An Intel® processor and chipset combined with an operating system and system firmware supporting Intel Hyper-Threading Technology enables:

- Running demanding applications simultaneously while maintaining system responsiveness
- Running multi-threaded applications faster to maximize productivity and performance
- Increasing the number of transactions that can be processed simultaneously
- Providing headroom for new solution capabilities and future needs

When Intel Hyper-Threading Technology and Intel Turbo Boost Technology are combined in processors based on Intel microarchitecture (Nehalem), these intelligent processors deliver better performance by dynamically adapting to the workload. They automatically take advantage of available headroom to increase processor frequency and maximize clock cycles on active cores to get the tasks done quicker.

3. Intel® Intelligent Power Technology

Intel Intelligent Power Technology is an innovation that monitors power consumption in servers to identify those that are not being fully utilized. It has two main features:

- Integrated Power Gates (see Figure 4) allow individual idling cores to be reduced to near-zero power independent of other operating cores, reducing idle power consumption to 10 watts, versus 16 or 50 watts in prior generations of Intel quad-core processors.³
- Automated Low-Power States automatically put processor and memory into the lowest available power states that will meet the requirement of the current workload. Because processors are enhanced with more and lower CPU power states, and the memory and I/O controllers have new power management features, the degree to which power can be minimized is now greatly enhanced.

4. Microarchitecture Enhancements

Intel microarchitecture (Nehalem) includes significant core enhancements to further improve the performance of the individual processor cores. Below we describe some of these enhancements.

Intel® Smart Cache Enhancements

Intel microarchitecture (Nehalem) enhances the Intel® Smart Cache by adding an inclusive shared L3 cache that can be up to eight megabytes (MB) in size. In addition to this cache being shared across all cores, the inclusive shared L3 cache can increase performance while reducing traffic to the processor cores. Some architectures use exclusive L3 cache, which contains data not stored in other caches. Thus, if a data request misses on the L3 cache, each processor core must still be searched (or snooped) in case their individual caches might contain the requested data. This can increase latency and snoop traffic between cores. With Intel microarchitecture (Nehalem), a miss of its inclusive shared L3 cache guarantees the data is outside the

Automatic Operation or Manual Core Control

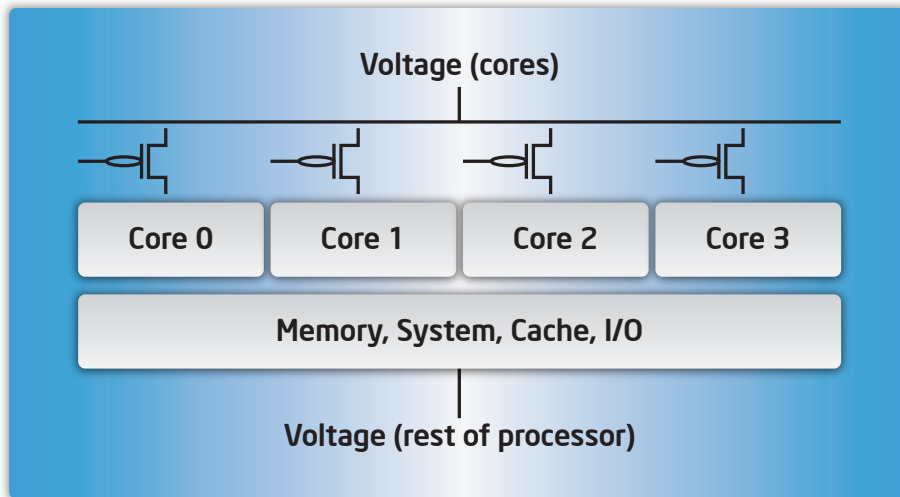

Figure 4. Integrated Power Gates enable idle cores to go to near-zero power independently.

processor and thus is designed to eliminate unnecessary core snoops to reduce latency and improve performance.

The new three-level cache hierarchy for Intel microarchitecture (Nehalem) consists of:

- Same L1 cache as Intel Core microarchitecture (32 KB Instruction Cache, 32 KB Data Cache)
- New L2 cache per core for very low latency (256 KB per core for handling data and instruction)
- New fully inclusive, fully shared 8 MB L3 cache (all applications can use entire cache)

Instructions per Cycle Improvements

The more instructions that can be run each clock cycle, the greater the performance. In many cases, by running more instructions in any given clock cycle, the work task can

complete sooner, enabling the processor to more quickly return to a lower power state. To run more instructions per cycle, Intel made several key innovations.

Greater Parallelism. One way to extract more parallelism out of software code is to increase the amount of instructions that can be run “out of order.” This enables more simultaneous processing. To be able to identify more independent operations that can be run in parallel, Intel increased the size of the out-of-order window and scheduler, giving them a wider window from which to look for these operations. Intel also increased the size of the other buffers in the core to ensure they wouldn’t become a limiting factor.

More Efficient Algorithms. With each new microarchitecture, Intel has included improved algorithms in places where

previous processor generations saw lost performance due to stalls (dead cycles). Intel microarchitecture (Nehalem) brings many such improved algorithms to increase performance. These include:

- **Faster Synchronization Primitives:** As multi-threaded software becomes more prevalent, the need to synchronize threads is also becoming more common. Intel microarchitecture (Nehalem) speeds up the common legacy synchronization primitives (such as instructions with a LOCK prefix or the XCHG instruction) so that existing threaded software will see a performance boost.
- **Faster Handling of Branch Mispredictions:** A common way to increase performance is through the prediction of branches. Intel microarchitecture (Nehalem) optimizes the cases where the predictions are wrong, so that the effective penalty of branch mispredictions overall is lower than on prior processors.
- **Improved Hardware Prefetch and Better Load-Store Scheduling:** Intel microarchitecture (Nehalem) continues the many advances Intel made with the Intel Core microarchitecture (Penryn) family of processors in reducing memory access latencies through prefetch and load-store scheduling improvements.

Enhanced Branch Prediction

Branch prediction attempts to guess whether a conditional branch will be taken or not. Branch predictors are crucial in today’s processors for achieving high performance. They allow processors to fetch and execute instructions without waiting for a branch

to be resolved. Processors also use branch target prediction to attempt to guess the target of the branch or unconditional jump before it is computed by parsing the instruction itself. In addition to greater performance, an additional benefit of increased branch prediction accuracy is that it can enable the processor to consume less energy by spending less time executing mispredicted branch paths.

Intel microarchitecture (Nehalem) uses several innovations to reduce branch mispredicts that can hinder performance and to improve the handling of branch mispredicts.

- **New Second-Level Branch Target Buffer (BTB).** To improve branch predictions in applications that have large code footprints (e.g., database applications), Intel added a second-level branch target buffer. BTBs reduce the performance penalty of branches in pipelined processors by predicting the path of the branch and caching information used by the branch.
- **New Renamed Return Stack Buffer (RSB).** RSBs store forward and return pointers associated with call and return instructions. Intel's new renamed RSB helps avoid many common return instruction mispredictions.

New Application Targeted Accelerators and Intel SSE4

Intel microarchitecture (Nehalem) includes all the additional Intel SSE4 instructions Intel included in Intel Core microarchitecture (Penryn) for faster computation/manipulation of media (graphics, video

encoding and processing, 3-D imaging, and gaming). In addition, Intel microarchitecture (Nehalem) adds seven new Application Targeted Accelerators for more efficient accelerated string and text processing of applications like XML.

Application Targeted Accelerators extend the capabilities of Intel® architecture by adding performance-optimized, low-latency, lower power fixed-function accelerators on the processor die to benefit specific applications. Such accelerators are the start of a natural evolution where gradually more and more advantageous implementations of fixed-function capabilities will be developed and added to the processor. Just as the evolution of silicon technology from 65nm to 45nm to 32nm enables more transistors for additional cores and cache, so too will it also enable more of these fixed-function on-die implementations. The benefit will be greater performance—and superior energy efficiency—for these specific applications.

The seven Application Targeted Accelerators included in Intel microarchitecture (Nehalem) provide new string and text processing instructions to improve performance of string and text processing operations. For example, they enable parsing of XML strings and text at a much higher speed. These Application Targeted Accelerators will be useful for lexing, tokenizing, regular expression evaluation, virus scanning, and intrusion.

Summary

Intel microarchitecture (Nehalem) represents the next level of multi-core performance, offering the latest in processor innovation. First appearing as the Intel® Core™ i7-900 processor series and now the foundation for the Intel Core i7-800 and Core i5-700 processor series; Intel microarchitecture (Nehalem) intelligently maximizes performance to match workloads. As a microarchitecture for desktop processors, it offers energy-efficient performance that scales energy use per performance demands while unleashing amazing parallel processing performance.

Intel® Core™ i7-800 Processor Series and the Intel® Core™ i5-700 Processor Series Based on Intel® Microarchitecture (Nehalem)

Learn More

For more information on Intel microarchitecture (Nehalem) including animations and podcasts, visit:

www.intel.com/technology/architecture-silicon/next-gen/index.htm

For more on Intel's 45nm Hi-k metal gate process technology,

see: www.intel.com/technology/45nm

For more on Intel SSE4, download the white paper, "Extending the World's Most Popular Processor Architecture," at:

download.intel.com/technology/architecture/new-instructions-paper.pdf

www.intel.com

¹ Hyper-Threading Technology requires a computer system with a processor supporting Hyper-Threading Technology and an HT Technology enabled chipset, BIOS and operating system. Performance will vary depending on the specific hardware and software you use. See www.intel.com/info/hyperthreading/ for more information including details on which processors support HT Technology. processor X5570, 2.93 GHz, 8 MB L3 cache, 6.4QPI, 24 GB memory (6x4 GB DDR3-1333).

² For a more in-depth discussion of how Intel Turbo Boost technology works, see: <http://download.intel.com/design/processor/applnots/320354.pdf>

³ Depending on processor SKU.

All products, platforms, dates, and figures specified are preliminary based on current expectations, and are subject to change without notice.

All data is based on comparisons of engineering data sheets or measurements using actual hardware or simulators.

Intel® Virtualization Technology requires a computer system with an enabled Intel® processor, BIOS, virtual machine monitor (VMM) and, for some uses, certain platform software enabled for it. Functionality, performance or other benefits will vary depending on hardware and software configurations and may require a BIOS update. Software applications may not be compatible with all operating systems. Please check with your application vendor.

INFORMATION IN THIS DOCUMENT IS PROVIDED IN CONNECTION WITH INTEL® PRODUCTS. NO LICENSE, EXPRESS OR IMPLIED, BY ESTOPPEL OR OTHERWISE, TO ANY INTELLECTUAL PROPERTY RIGHTS IS GRANTED BY THIS DOCUMENT. EXCEPT AS PROVIDED IN INTEL'S TERMS AND CONDITIONS OF SALE FOR SUCH PRODUCTS, INTEL ASSUMES NO LIABILITY WHATSOEVER, AND INTEL DISCLAIMS ANY EXPRESS OR IMPLIED WARRANTY, RELATING TO SALE AND/OR USE OF INTEL PRODUCTS INCLUDING LIABILITY OR WARRANTIES RELATING TO FITNESS FOR A PARTICULAR PURPOSE, MERCHANTABILITY, OR INFRINGEMENT OF ANY PATENT, COPYRIGHT OR OTHER INTELLECTUAL PROPERTY RIGHT. UNLESS OTHERWISE AGREED IN WRITING BY INTEL, THE INTEL PRODUCTS ARE NOT DESIGNED NOR INTENDED FOR ANY APPLICATION IN WHICH THE FAILURE OF THE INTEL PRODUCT COULD CREATE A SITUATION WHERE PERSONAL INJURY OR DEATH MAY OCCUR.

Intel may make changes to specifications and product descriptions at any time, without notice. Designers must not rely on the absence or characteristics of any features or instructions marked "reserved" or "undefined." Intel reserves these for future definition and shall have no responsibility whatsoever for conflicts or incompatibilities arising from future changes to them. The information here is subject to change without notice. Do not finalize a design with this information.

The products described in this document may contain design defects or errors known as errata which may cause the product to deviate from published specifications. Current characterized errata are available on request. Contact your local Intel sales office or your distributor to obtain the latest specifications and before placing your product order. Copies of documents which have an order number and are referenced in this document, or other Intel literature, may be obtained by calling 1-800-548-4725, or by visiting Intel's Web site at www.intel.com.

Copyright © 2009 Intel Corporation. All rights reserved. Intel, the Intel logo, Intel Core, Xeon Inside, and Xeon are trademarks of Intel Corporation in the U.S. and other countries.

